

QUECTEL\_LOGO  
QuecPython

EC600X

Title		
Size	Number	Revision
A2		
Date	2021/4/23	Sheet of
File	EC_600S_S84Doc	Drawn By:

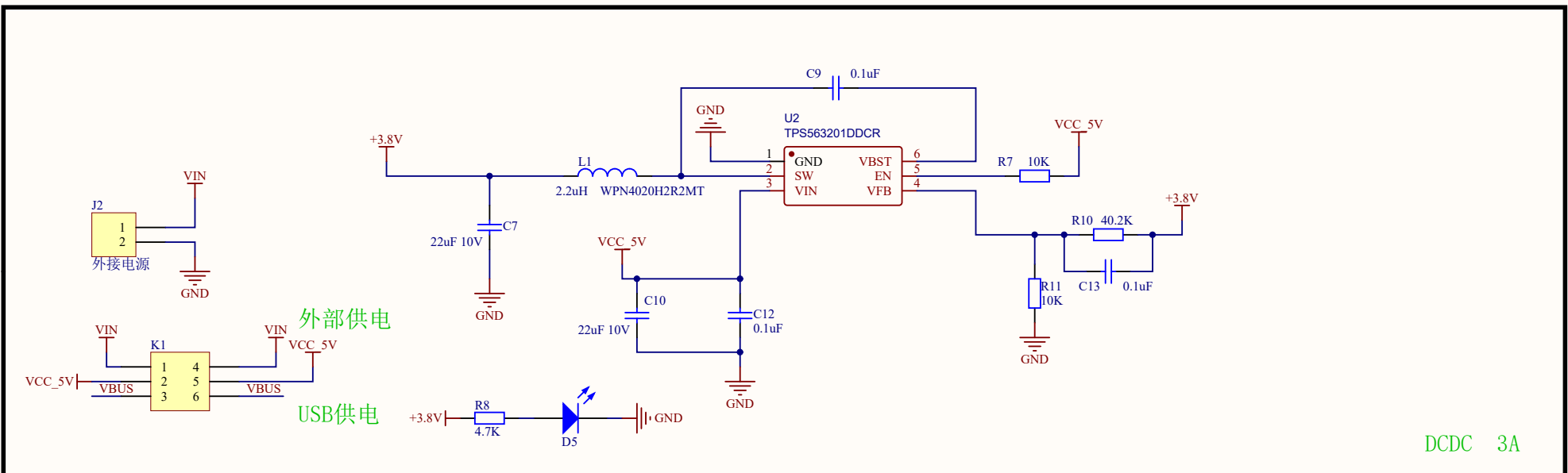

DCDC 3A

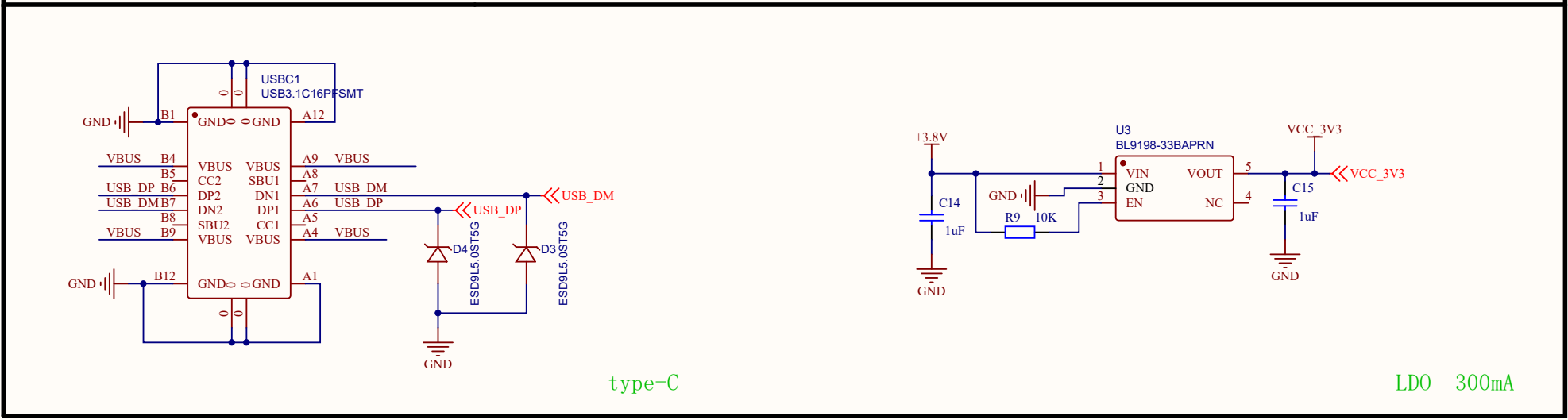

LDO 300mA

Title		
Size	Number	Revision
A4		
Date:	2021/4/23	Sheet of
File:	E:\...\2.POWER.SchDoc	Drawn By:

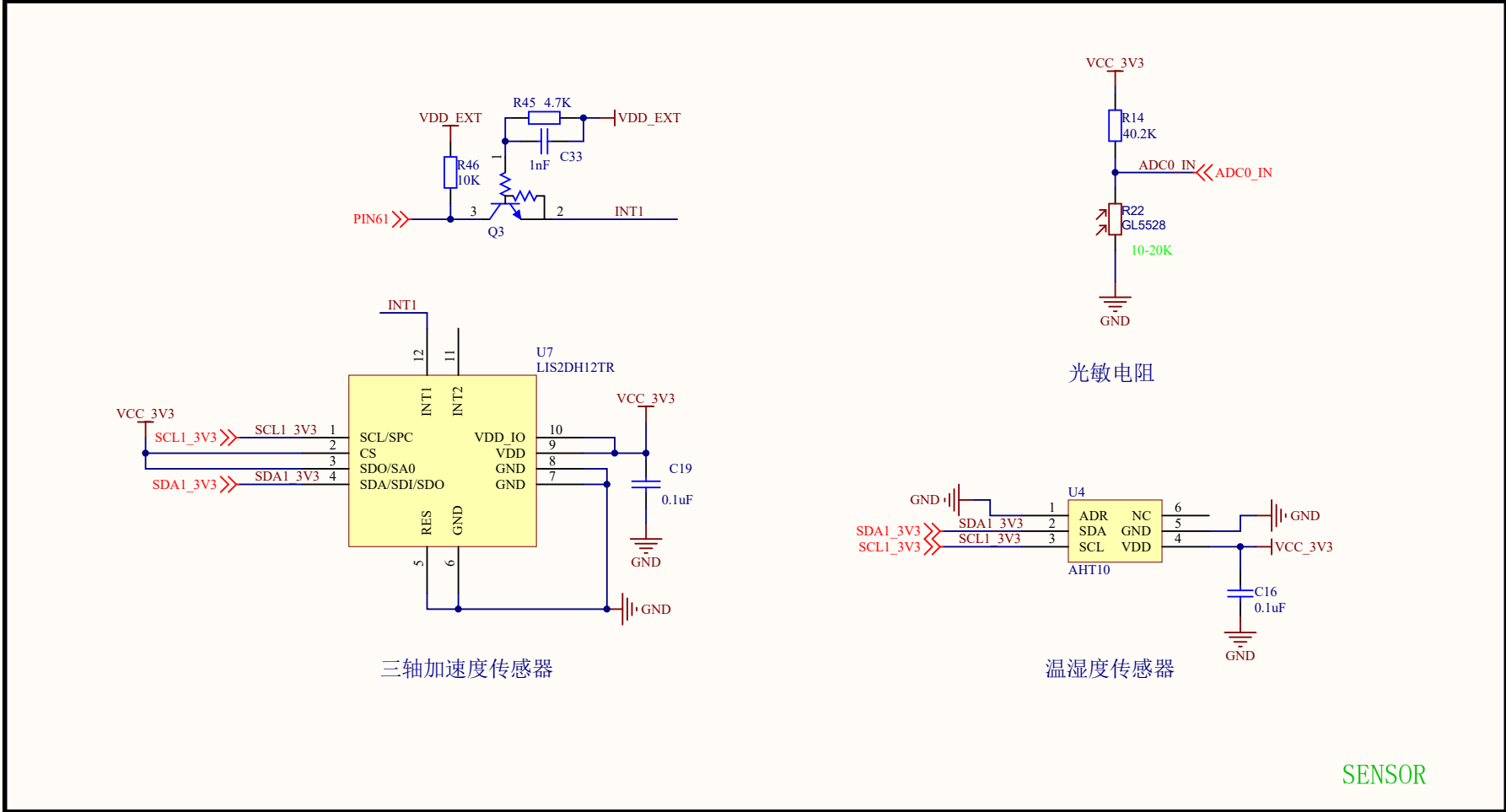

SENSOR

Title		
Size	Number	Revision
A4		
Date:	2021/4/23	Sheet of
File:	E:\...3.SENSOR+EEPROM.SchDoc	Drawn By:

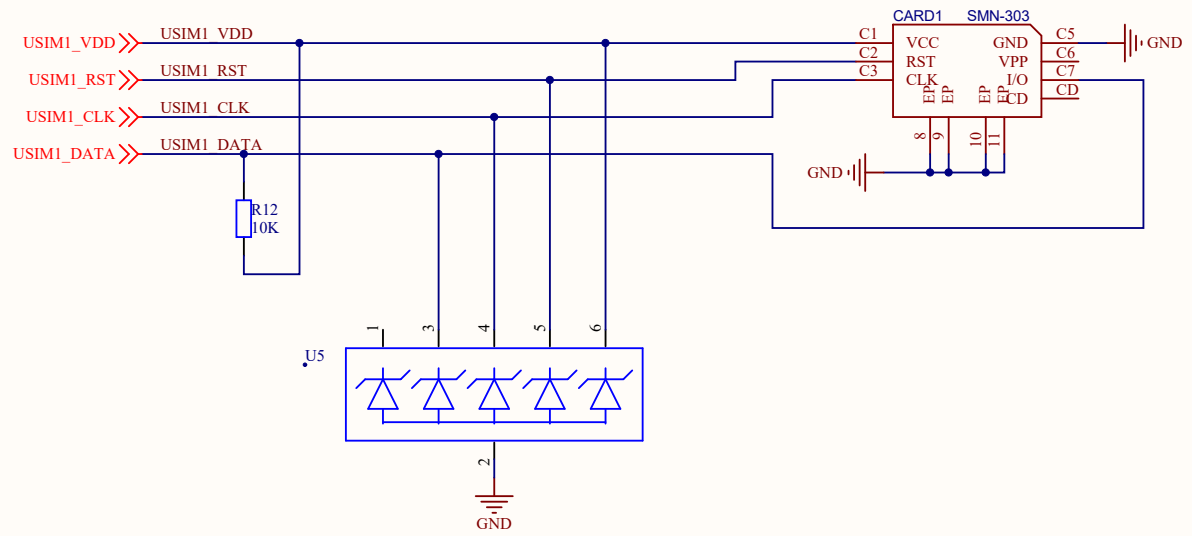

USIM

Title		
Size	Number	Revision
A4		
Date:	2021/4/23	Sheet of
File:	E:\...4.SIM-CARD.SchDoc	Drawn By:

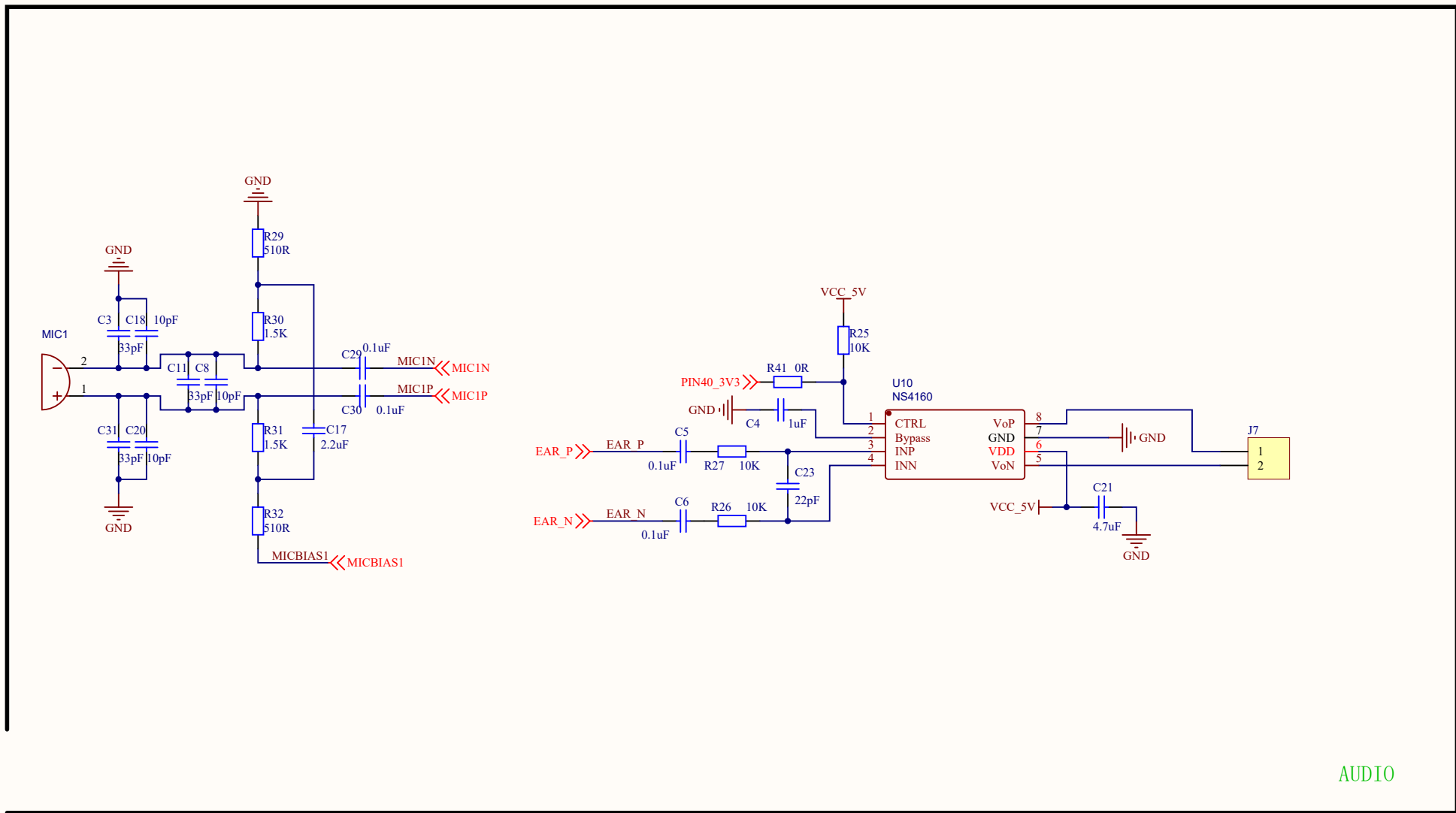

AUDIO

Title		
Size	Number	Revision
A4		
Date:	2021/4/23	Sheet of
File:	E:\...\5.AUDIO.SchDoc	Drawn By:

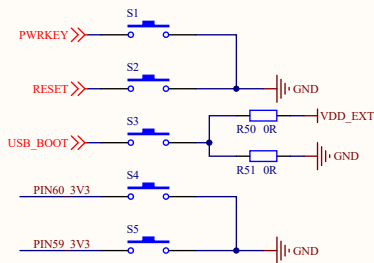
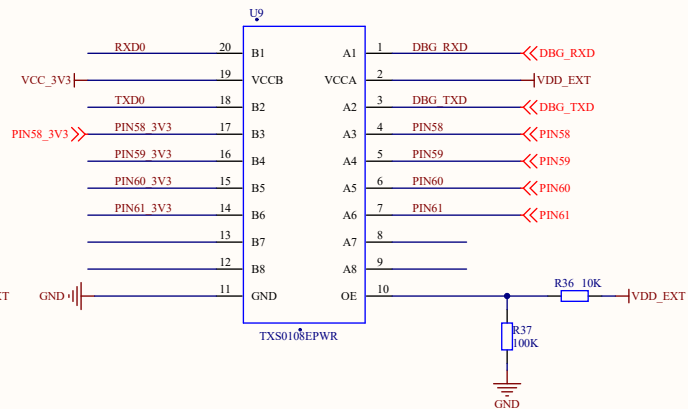
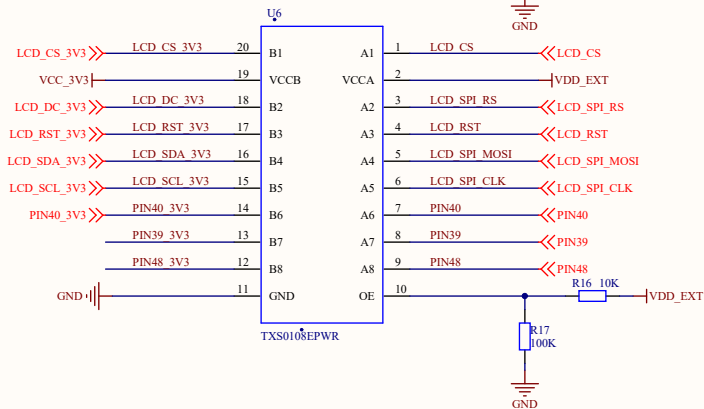
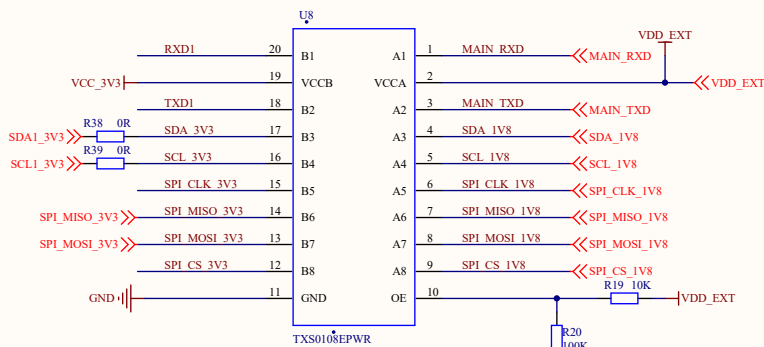
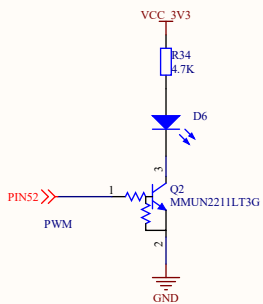
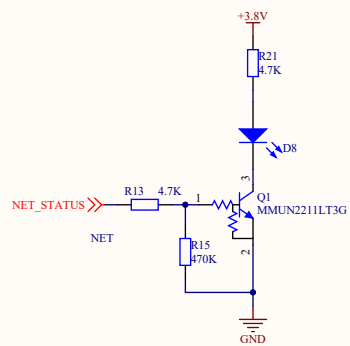

EC600S/EC600U贴R50  
EC600N贴R51

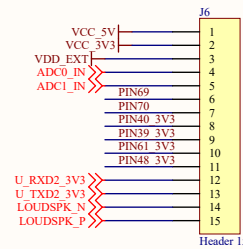
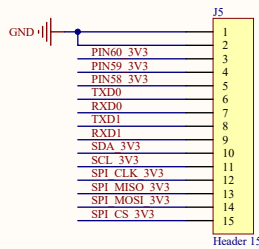

GPIO

Title		
Size	Number	Revision
A3		
Date:	2021/4/23	Sheet of
File:	E:\6.GPIO+UART.SchDoc	Drawn By:

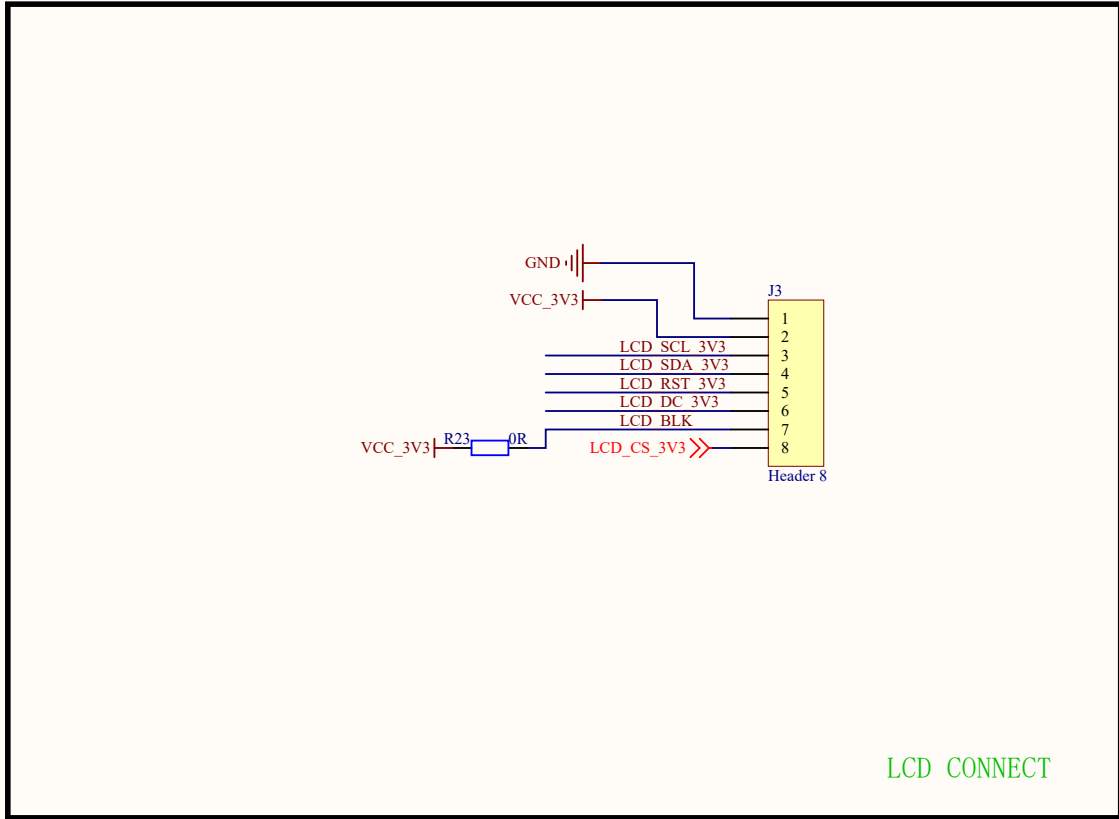

LCD CONNECT

Title		
Size	Number	Revision
A4		
Date:	2021/4/23	Sheet of
File:	E:\...\7.LCM.SchDoc	Drawn By:

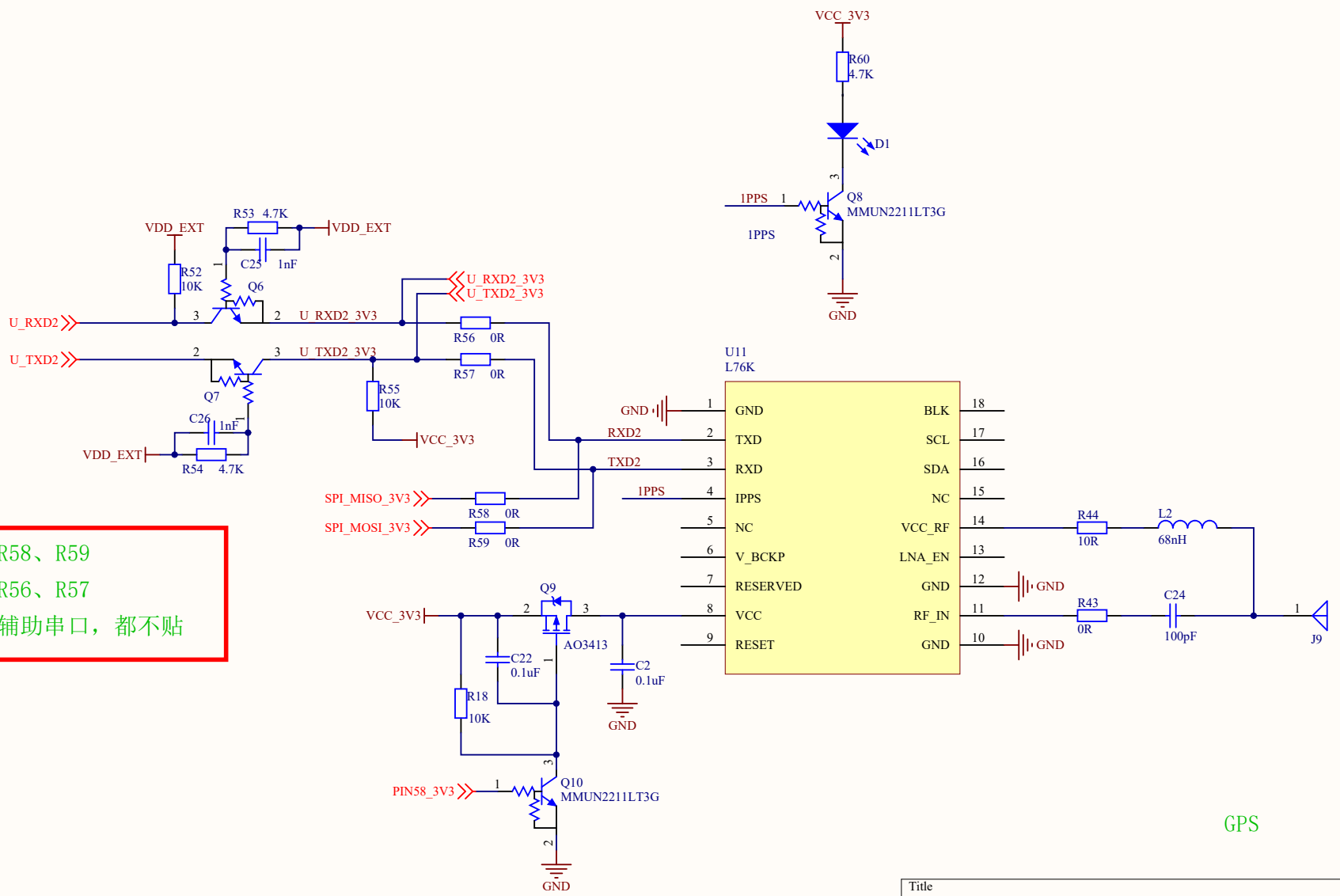

EC600S贴R58、R59  
 EC600U贴R56、R57  
 EC600N无辅助串口，都不贴

GPS

Title		
Size	Number	Revision
A4		
Date:	2021/4/23	Sheet of
File:	E:\...\8.GPS.SchDoc	Drawn By: